

DTC	P0037	OXYGEN SENSOR HEATER CONTROL CIRCUIT LOW (BANK 1 SENSOR 2)
------------	--------------	---

DTC	P0038	OXYGEN SENSOR HEATER CONTROL CIRCUIT HIGH (BANK 1 SENSOR 2)
------------	--------------	--

CIRCUIT DESCRIPTION

Refer to DTC P0136 on [page 05-81](#).

HINT:

The ECM provides a pulse width modulated control circuit to adjust current through the heater. The heated oxygen sensor heater circuit uses a relay on the +B side of the circuit.

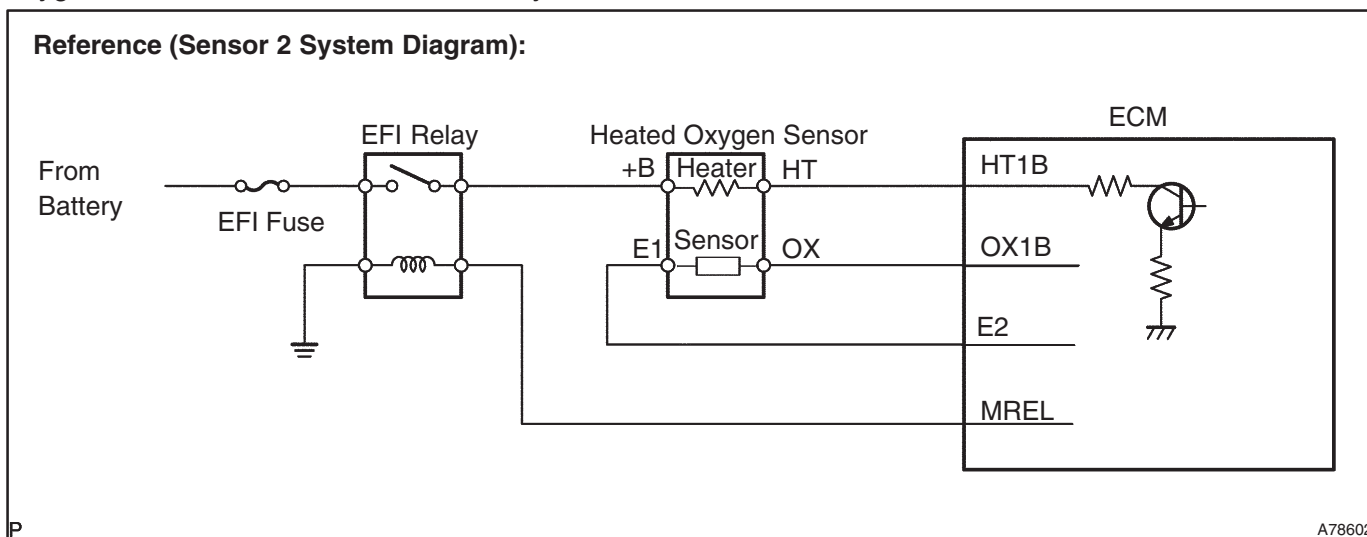

DTC No.	DTC Detection Condition	Trouble Area
P0037	Heated current is 0.3 A or less when heater operates (1 trip detection logic)	<ul style="list-style-type: none"> • Open in heater circuit of heated oxygen sensor • Heated oxygen sensor heater (sensor 2) • EFI relay • ECM
P0038	Heater current exceeds 2 A when heater operates (1 trip detection logic)	<ul style="list-style-type: none"> • Short in heater circuit of heated oxygen sensor • Heated oxygen sensor heater (sensor 2) • EFI relay • ECM

HINT:

Sensor 2 refers to the sensor mounted behind the TWC and located far from the engine assembly.

WIRING DIAGRAM

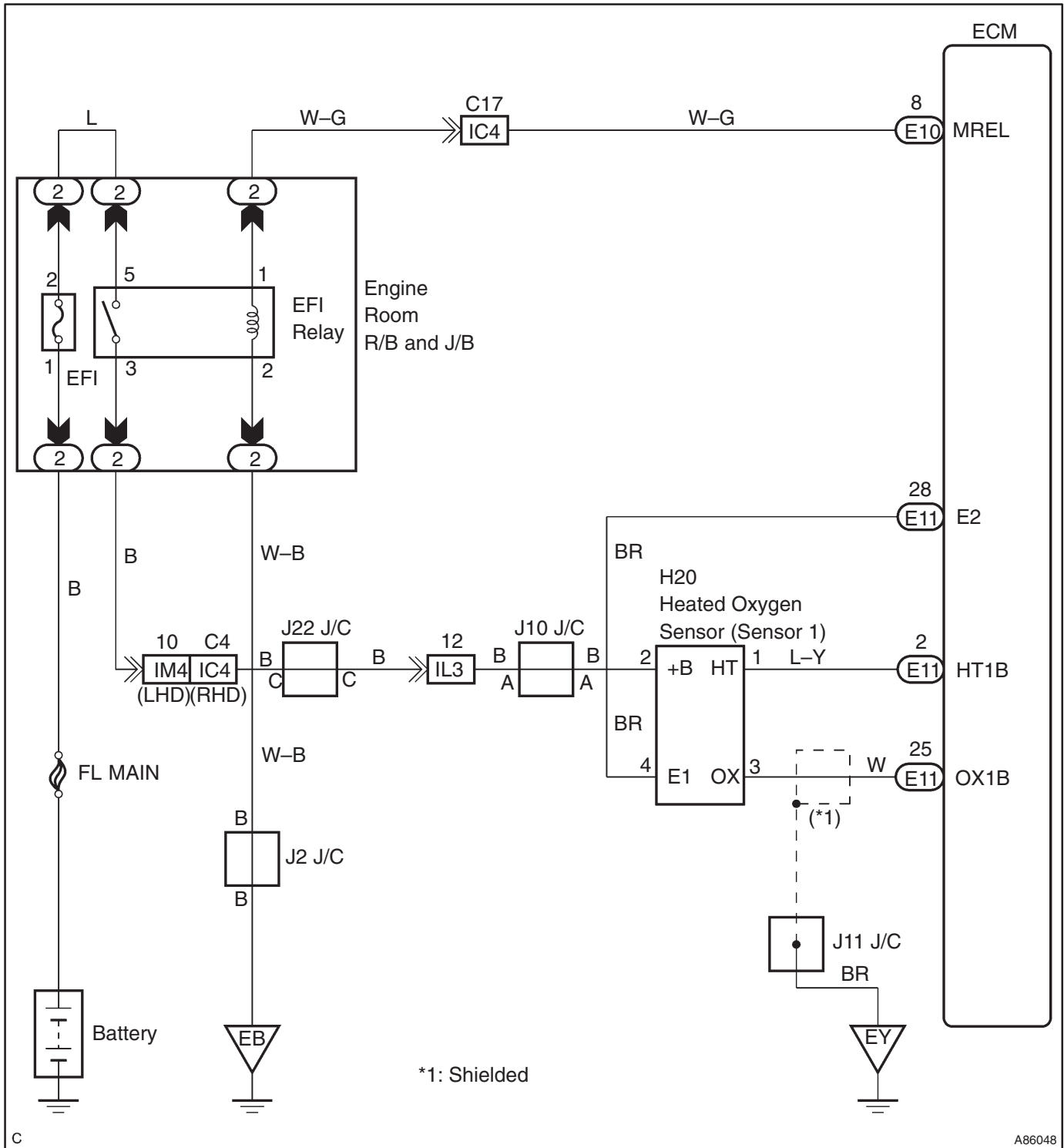

INSPECTION PROCEDURE

HINT:

Read freeze frame data using the intelligent tester II. Freeze frame data record the engine condition when malfunctions are detected. When troubleshooting, freeze frame data can help determine if the vehicle was moving or stationary, if the engine was warmed up or not, if the air-fuel ratio was lean or rich, and other data from the time the malfunction occurred.

1 INSPECT HEATED OXYGEN SENSOR(HEATER RESISTANCE)

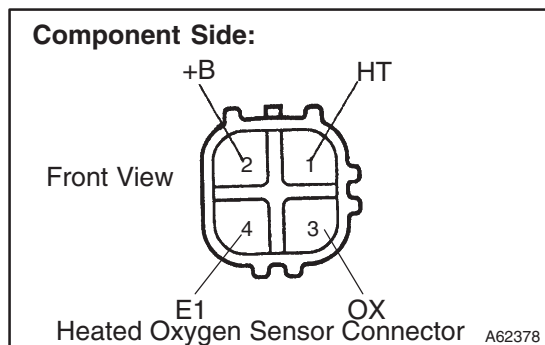

- Disconnect the H2O heated oxygen sensor connector.
- Measure the resistance according to the value(s) in the table below.

Standard:

Tester Connection	Specified Condition
1 (HT) – 2 (+B)	11 to 16 Ω at 20°C (68°F)
1 (HT) – 4 (E1)	10 k Ω or higher

- Reconnect the heated oxygen sensor connector.

NG → REPLACE HEATED OXYGEN SENSOR

OK

2 INSPECT EFI RELAY

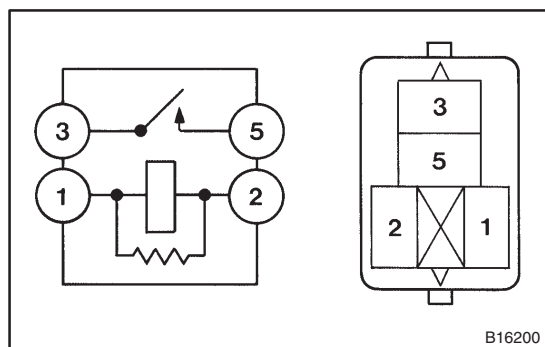

- Remove the EFI relay from the engine room R/B.
- Check the EFI relay resistance.

Standard:

Tester Connection	Specified Condition
3 – 5	10 k Ω or higher
3 – 5	Below 1 Ω (when battery voltage applied to terminals 1 and 2)

- Reinstall the EFI relay.

NG → REPLACE EFI RELAY

OK

3 INSPECT ECM(HT1B VOLTAGE)

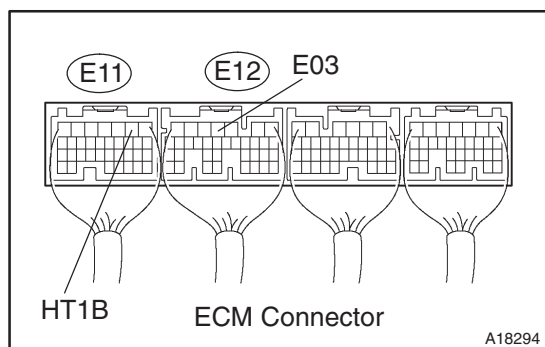

- Turn the ignition switch to ON.
- Measure the voltage according to the value(s) in the table below.

Standard:

Tester Connection	Specified Condition
HT1B (E11-2) – E03 (E12-4)	9 to 14 V

OK → REPLACE ECM (See page 10-12)

NG

4 CHECK HARNESS AND CONNECTOR(HEATED OXYGEN SENSOR - ECM, HEATED OXYGEN SENSOR - EFI RELAY)

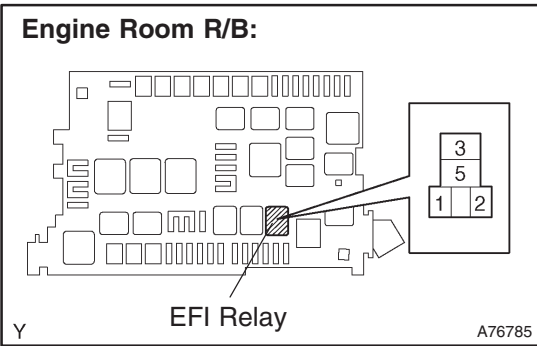
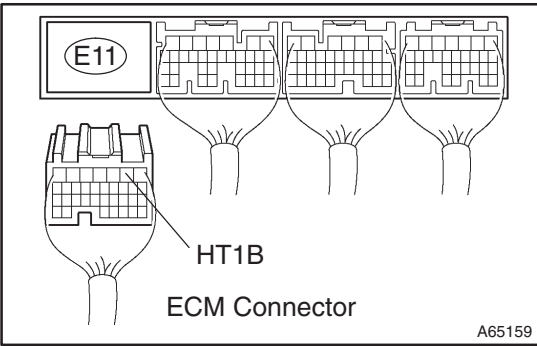
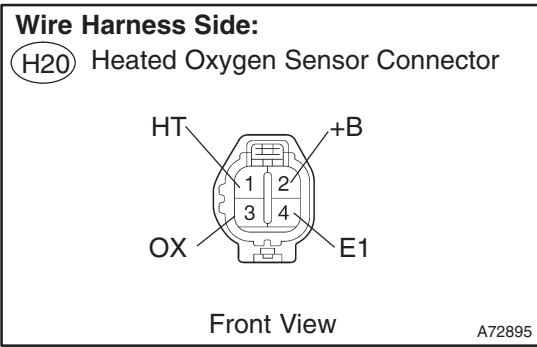

- (a) Check the harness and the connectors between the ECM and heated oxygen sensor.
- (1) Disconnect the H20 heated oxygen sensor connector.
 - (2) Disconnect the E11 ECM connector.
 - (3) Measure the resistance according to the value(s) in the table below.

Standard (Check for open):

Tester Connection	Specified Condition
HT (H20-1) - HT1B (E11-2)	Below 1 Ω

Standard (Check for short):

Tester Connection	Specified Condition
HT (H20-1) or HT1B (E11-2) - Body ground	10 kΩ or higher

- (4) Reconnect the heated oxygen sensor connector.
 - (5) Reconnect the ECM connector.
- (b) Check the harness and the connectors between the heated oxygen sensor and EFI relay.
- (1) Disconnect the H20 heated oxygen sensor connector.
 - (2) Remove the EFI relay from the engine room R/B.
 - (3) Measure the resistance according to the value(s) in the table below.

Standard (Check for open):

Tester Connection	Specified Condition
+B (H20-2) - EFI relay (3)	Below 1 Ω

Standard (Check for short):

Tester Connection	Specified Condition
+B (H20-2) or EFI relay (3) - Body ground	10 kΩ or higher

- (4) Reconnect the heated oxygen sensor connector.
- (5) Reinstall the EFI relay.

NG REPAIR OR REPLACE HARNESS OR CONNECTOR

OK

REPLACE ECM (See page 10-12)